

Assembly Instructions for FK603 (2W Stereo Power Amp)

What it does:

This circuit is designed to amplify low level audio signals and play them out over the two speakers. It accepts two different channels in (stereo) and will play them out over separate speakers. It has on-board volume control for each of the channels.

What we are making:

This system is ideal for an audio docking station for mobile phones, radios, computers, etc.



Fig 1: Finished Product

KitStop and KitStop Electronics are Trading Names owned by
John G Perrin ABN 97 328 643 035

Address: P.O. Box 141, Poowong ,Victoria 3988 Australia.
Phone +61 (0) 407 301 239

www.kitstop.com.au

Assembly Instructions for FK603 (2W Stereo Power Amp)

Technical Specs:

- Power supply: 9-12VDC
- Current Average: 600mA when using 12V DC and driving into 8Ohm speakers .
- Max output power: 2W
- Volume control equipped
- Voltage Gain (at Freq 1kHz): 34dB
- S/N ratio: 80dB
- Frequency Response : 25Hz to 20kHz @ -3dB
- Distortion (*Speakers = 8 Ohms, Pout = 500mW, Freq = 1kHz*): < 0.5%
- PCB dimensions: 56.4 x 48.0 mm

How it works:

The system consists of two identical amplifiers. One drives the "Left" Channel, and the other drives the "Right" channel.

We will discuss one channel in depth, and allow the reader to infer the other channel.

The audio input signal is passed through the input capacitor (C1) . It is then "divided" by the volume control potentiometer (VR1) to give anything from full input strength down to almost zero input strength.

The "divided" signal is then fed into the pin3 of the Audio Amplifier IC (TBA820M) .

The output of the Audio Amplifier IC (pin5) is coupled via C8 to the output pin. C3 and R3 are used to remove the risk of any unwanted high frequency oscillations (heard by us as "Squeals").

The "Gain" of the amplifier is controlled by C5 and R1. (Note: this "Gain control" is a function of the TBA820M IC).

Assembly Instructions for FK603 (2W Stereo Power Amp)

Circuit Diagram:

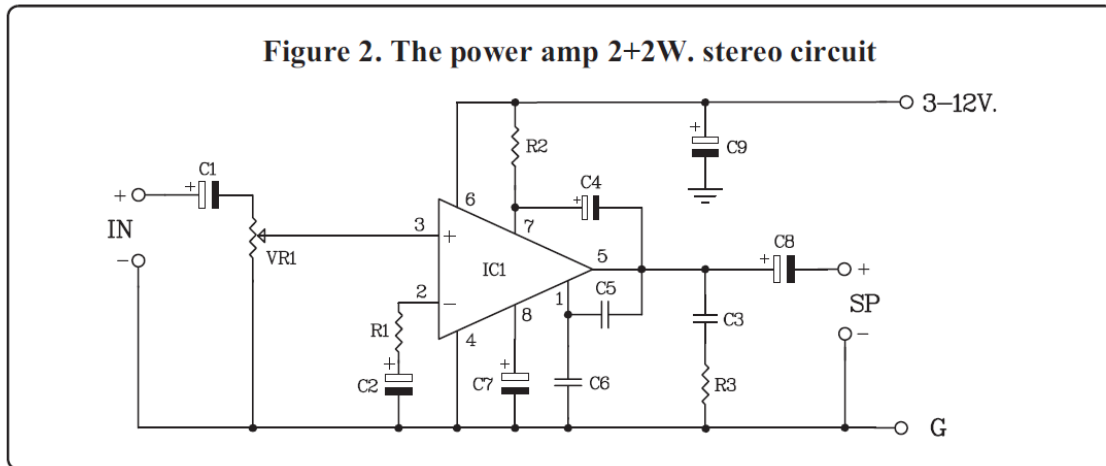

Fig 2: Circuit Diagram for one channel of the system.

How to build it:

Step 1. Installing the resistors.

Resistors:

R1 (twice)	120 Ω	-brown-red-brown-gold
R2 (twice)	56 Ω	-green-blue-black-gold
R3 (twice)	1 Ω	-brown-black-gold-gold
Jumper	0 Ω	- Use cut off leg from resistor

Fig 3.1 Resistor Values

By referring to Fig 3.1 determine the value of each resistor and place them in their correct positions as indicated on the printed circuit board (PCB).

Do this by carefully bending their wires down to form a 'U' shape and poke through the holes in the PCB as shown in Fig3.2.

Assembly Instructions for FK603 (2W Stereo Power Amp)

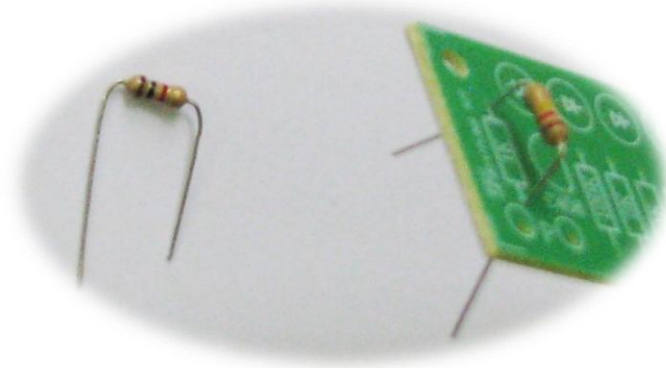

Fig 3.2 Installing Resistors

Note that there are two sets of each resistor plus one "Jumper" which need to be installed!

As far as possible, try to keep the resistors "oriented" in the same direction. (Try to keep the gold band at the same end of the installed resistors.) See Fig 3.3 for a suggested pattern.

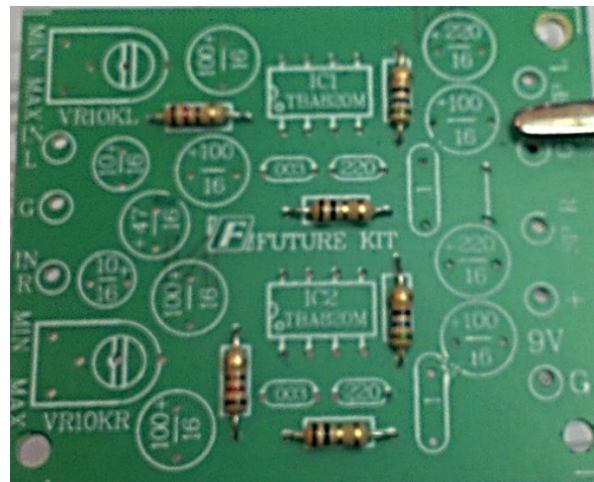

Fig 3.3 Installing Resistors with consistent orientation.

Once they are in the correct positions solder them into place and trim the excess wire.

We strongly suggest that you install the "jumper" at this stage. You can simply use one of the trimmed legs of the resistors for making the "Jumper". Refer to Fig 3.4 for an example of a "Jumper" which we made.

Assembly Instructions for FK603 (2W Stereo Power Amp)



*Fig 3.4 Study of the “Jumper” which we made from the cut off leg of a resistor.
(Shown larger than real-life size).*

The “jumper” location is identified in Fig 3.5.

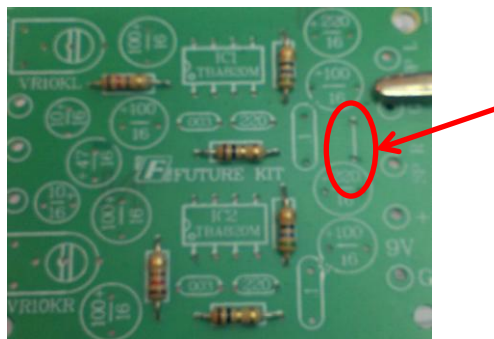

Fig 3.5 Identifying the “Jumper” location .

Step 2. Installing the Capacitors

Carefully identify all the different capacitors to be used.

There are three “families” of capacitors used in this kit. These are “Electrolytic” Capacitors , “Mylar” Capacitors and “Ceramic” Capacitors

Refer to Fig 3.6 to determine the values of the different capacitors.

Capacitors:		
Electrolytic Caps:		
C1	10 μ F	
C2,C4,C7	100 μ F	
C8	220 μ F	
C9	47 μ F	
Mylar Caps:		
C3	0.1 μ F	Marking = “104”
Ceramic Caps:		
C5	220pF	Marking = “221”
C6	3nF (or 3.3nF in some kits)	Marking = “302” (or “332”)

Fig 3.6 Identifying the Capacitor markings .

Assembly Instructions for FK603 (2W Stereo Power Amp)

Step 3. IC Sockets

Carefully insert the IC Sockets.

Take particular care to identify and then align the "notch" which identifies the orientation for the socket and the IC to follow.

For extra information, please view the drawings on the back of the FK675 packet.

Step 4. The Volume "Trim pots" (Trimmer Potentiometers):

Carefully align the three legs of the Trim pots (VR1 and VR2) with the mounting holes. *(Please note that there are several different styles and sizes of trim pots, hence the board has been laid out to accept any of three different sized trim pots.)*

Refer to Fig 3.7 to see a sample of mounted trim pots.

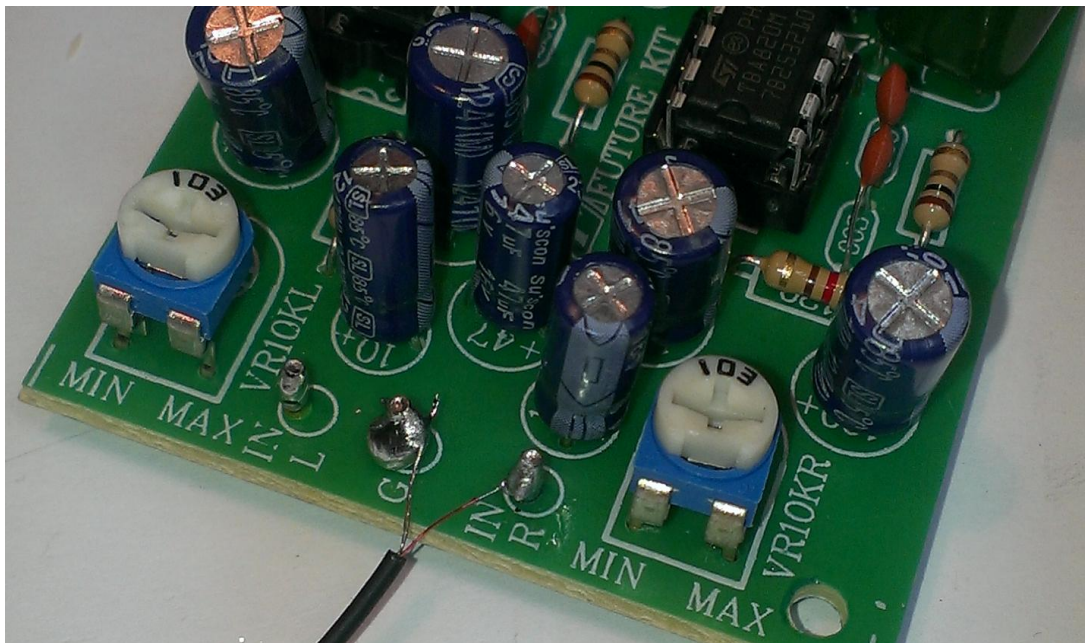

Fig 3.7 Showing the trim pots installed .

Step 5. Insert the "Stakes" and Standoffs.

These are the short, thick gold pins which are inserted from the rear of the PCB, and then soldered into place.

Step 6. Install the IC's.

Carefully orient the IC's to ensure that their "notches" are aligned with the markings on the PCB!

Assembly Instructions for FK603 (2W Stereo Power Amp)

Step 7. Connecting wires, speakers and Battery snap.

Once the standoffs are set, 'tin' each with solder. (For more information on "tinning", please refer to our separate document "Towards Better Soldering"). The battery snap can be soldered into place by 'tinning' the leads and ensuring the black wire is attached to the 'ground' (G) or negative (-) pole and the red wire to the positive (+).

The input should be soldered onto the three input stakes.

Finally the four standoffs can be connected to the speakers. Take note to connect the "-" side of each speaker to the Ground standoff. (Marked "G").

The "+" pin of one speaker should be connected to the "Speaker Right" standoff (marked "SP R"), and then the other speaker connected to the "Speaker Left" standoff (marked "SP L").

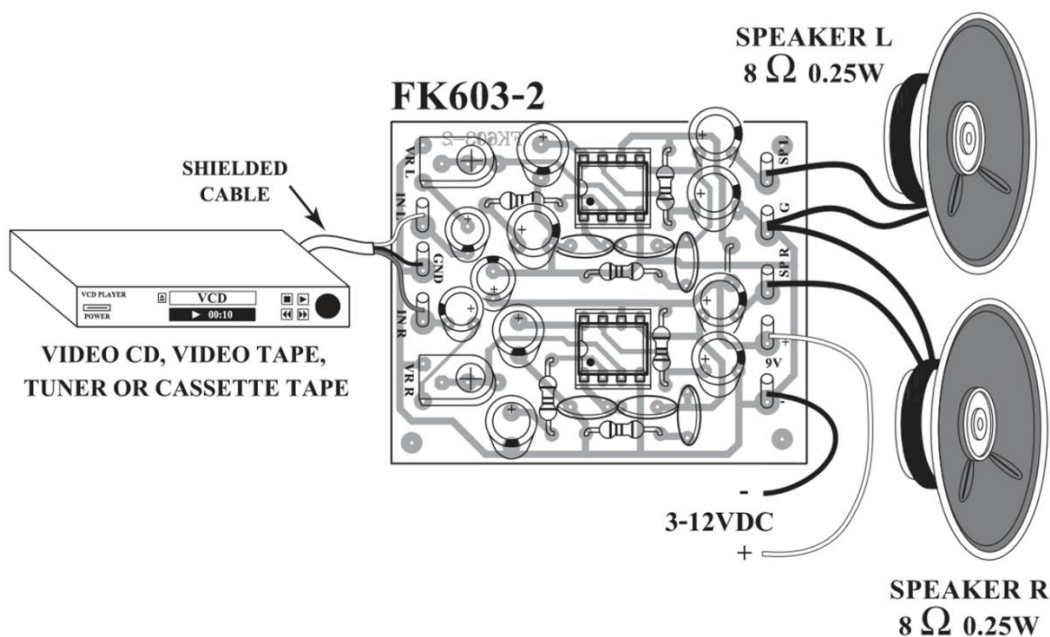

Fig 4 Attaching the wires

Testing:

Do not connect any input sound source yet!

We must first check the system has been constructed correctly!

Apply the power supply at 9V DC.

Watch for any sparks or signs of overheating.

If you see any sparks:

Assembly Instructions for FK603 (2W Stereo Power Amp)

- Do not worry (yet). It is common for many circuits which have a lot of capacitors in them (like this one) to draw a large "inrush" current at the first contact.
- Disconnect the power immediately.
- Test for any "hot spots".
- If no obvious hot spots, then
 - o Reconnect the power and watch for sparks a second time.
 - o If NO sparks a second time, this is normal! Things are looking good!
 - o If you continue to see sparks, you will need to recheck all your soldering for any "short Circuit" bridges.
- If you find a "hot spot" :
 - o Check for solder bridges which are causing a short circuit somewhere.
 - o Check that all components have been inserted correctly.
 - o Check for any loose "wire" off cuts which may be causing a short circuit.

Once you have the power connected and no signs of other problems, it is time to apply an audio signal.

-Turn the trim pots fully anticlockwise (Volume is down as much as possible).

- Now apply the audio source .

- Slowly turn the volume trim pot clockwise.

- The volume of the output should rise with the trim pot turning.

- If the quality of the output sound starts to deteriorate, it is possible that the volume of the input is exceeding the limits of the system. Therefore it may be that you have reached the usable limit of the input!

Care and Warnings:

The audio amp IC (TBA820M) is rated to a maximum of +12V DC. Do not apply any voltage above this. *(We recommend operating with a 9V DC battery as the power source for the first testing!)*

Most of the problems we have experienced with this kit are one of three kinds:

- 1) Soldering induced problems. (Short circuit bridges as well as poor quality "cold solder joints")
- 2) Component misplaced or misaligned.
- 3) Wire connections intermittent.